

MURPHYMATIC® Engine Micro-Controller

AEC-97079B
Revised 07-99
Catalog Section 40
(00-02-0097)



A91 Series

- Microprocessor Based Automatic Controller
- Field Programmable Trip Points
- Five LED Signal Indicators
- Startup Lockout Timer
- Interfaces With Other Existing Murphy Products
- NEMA 3R “Weatherproof” Enclosure

Description

A completely unattended startup/shutdown and run controller for engine driven equipment. This user friendly, compact, state-of-the-art microprocessor based controller, covers all basic start stop operations plus other features only found on more sophisticated and expensive controllers.

The A91 is designed to operate from a 12 or 24 volt battery, and requires a magnetic sensor (pick-up) for speed detection. It includes features, such as crank and rest cycles, time delay lockouts, sensing circuit for crank disconnect and over-speed, time delays before start and stop. Warmup and cool down are connected only on the WC model. Four LED's indicate shutdown for: low lube oil, high temperature, over crank and over-speed, and are reset by turning the power off. A fifth LED for engine running indicates when crank disconnect occurs.

The micro-controller is available in several configurations and is factory programmed. Certain parameters can be field adjusted without altering the basic control program. Custom programming of the microchip is available to OEM's and quantity orders.

The A91 is housed in a NEMA 3R enclosure with a hinged and gasketed dead front door. This weatherproof enclosure includes two 1/2 in. conduit holes, [7/8 in. (22 mm) diameter] in the bottom for input and output wiring.

All of the electrical components are installed on a “box” shaped, hinged front sub panel assembly. This working assembly can be purchased and installed in the user's choice of enclosures.

Applications

A variety of applications can be covered with the micro-controller such as:

- Air/Gas Compressors
- Standby Generator Sets
- Fire/Pipeline/Emergency Flood Pumps
- Booster/Transfer Pumps
- Municipal Fresh/Waste Water Treatment
- Sewage Lift Stations

Models Available

A91: For less than 5 amp current draw up to 24 VDC electric run output*

A91-S: For 10 amp current draw up to 240 VDC electric run output*

A91-WC: Same as A91 — with a warmup/cool-down relay.

A91-S-WC: Same as A91-S — with a warmup/cool-down relay.

Any Model -LC: Less weatherproof enclosure.

*Run output is the voltage and current required for an ignition system, fuel valve, or solenoid actuator that allows the engine to run.

Warranty

A limited warranty on materials and workmanship is given with this FW Murphy product. A copy of the warranty may be viewed or printed by going to www.fwmurphy.com/support/warranty.htm

Features

The A91 Series combines the advantages of solid state microprocessor control logic with the dependability of Murphy's experience in Engine Automation Systems. This engine controller eliminates the need for most electromechanical logic and control relays, while providing built-in design features:

- Applicable to All Types of Engines
- Built-in Speed Sensing Circuit with:
 - Adjustable Crank Disconnect RPM
 - Adjustable Over speed RPM
- Three-position Selector Switch allows for “Automatic”, “Off” or “Test” mode.
- Engine Running LED indicator
- Four First-Out Shutdown LED indicators for:
 - Low Lube Oil
 - High Temperature
 - Overcrank
 - Overspeed
- Quality 16 point Terminal Block
- Either start from remote contact close to start, open to stop, or N.O. contacts close to start, close to stop.
- Relays are plug-in type with LED indicator for fast service and maintenance.

Optional Features

- S:** Includes a relay to isolate magneto and capacitor discharge ignition systems.
- WC:** Includes a relay for loading and unloading driven equipment for engine warmup and cooldown.

Specifications

Power Input: 12 or 24 VDC nominal (specify).

Standby Power Consumption: <50mA.

Magnetic Pickup Input: Requires 2 V rms minimum.

Sensor Input Polarity: Negative (-).

Outputs: Five (5) open collector transistor 500 mA sink.

Two (2) relay, 5 Amp maximum at 12 or 24 VDC (sourcing).

Reverse Polarity Protection: 200 volt peak reverse voltage.

On-board Memory: 8k PROM (programmable, read only memory); data retention 10 years.

Operating Temperature Range: -20 to 140°F (-25 to 60°C).

Operating Humidity Range: 0-95% Non-Condensing

User Trip point Adjustments: Five (5) on-board potentiometers (320° turn).

Test-Off-Automatic Toggle Switch: Three position switch for:

- Test: Starts engine in automatic mode and runs until switched "off" or emergency shutdown occurs.
- Off: Disconnects all power to control circuits, Stop/disables engine from starting and resets shutdown indicators.
- Auto: Automatic start/stop sequencing is initiated by external switches and signals.

Cycle Crank Timer: 5 crank attempts 7 seconds each; 4 rest periods 15 seconds each, before overcrank.

Overspeed Trip Point Setting: From 2500-9000 Hz.

Crank Disconnect Speed Setting: From 400-2500 Hz.

Shutdown Time Delay: 15 seconds after engine start; locks out low lube oil and high temperature.

Engine Run LED: Turns "on" when crank disconnect occurs.

Shutdown Output: Removes DC output or operates dry relay contacts for engine shutdown (depending on model used).

Start/Stop: SPDT momentary; or SPST maintained switches.

Warmup Time Delay: Field adjustable from 0-300 seconds to load the engine after warmup (model -WC only).

Cooldown Time Delay: Field adjustable from 0-300 seconds (model -WC only).

Enclosure: Weatherproof NEMA 3R.

Enclosure Coating: Red enamel.

Subpanel Coating: White enamel.

Shipping Weight: 17 lb. (8 kg); subpanel: 7 lb (3.2 kg).

Shipping Dimensions: 12 x 12 x 9 in. (305 x 305 x 229 mm).

Accessories

MP3298: Magnetic pickup.

00002062: 12 V auxiliary starter solenoid.

00002063: 24 V auxiliary starter solenoid.

AT67207: Throttle controller.

CO3: Clutch actuator.

Dimensions

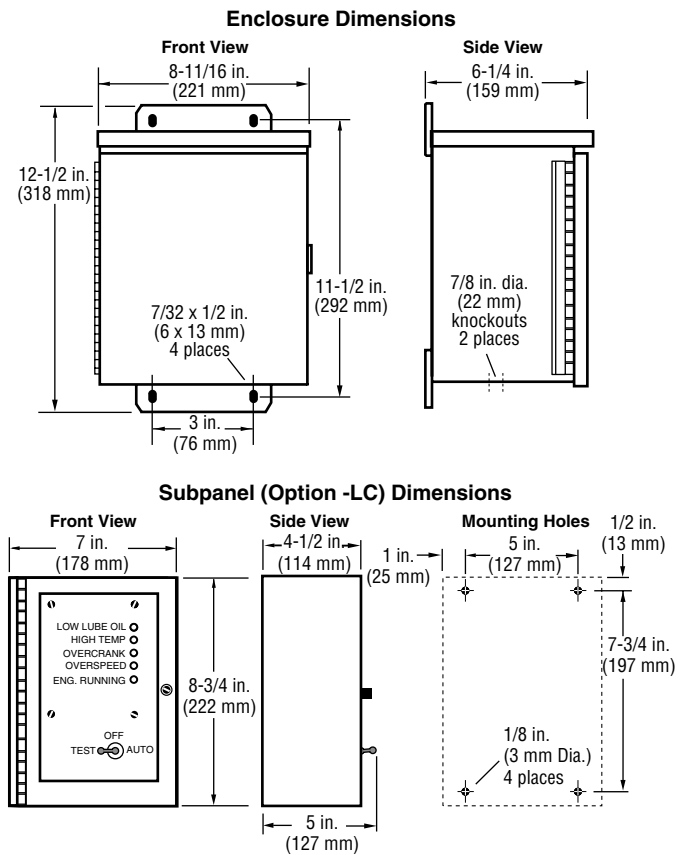

How to Order

NOTE: Run output is 5 amp @ 12 or 24 VDC. Run output is the voltage required for an ignition system, fuel valve, or solenoid actuator that allows the engine to run.

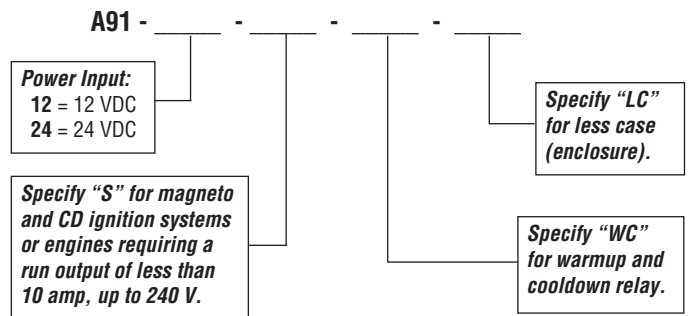

FW Murphy
 P.O. Box 470248
 Tulsa, Oklahoma 74147 USA
 +1 918 317 4100
 fax +1 918 317 4266
 e-mail sales@fwmurphy.com
 www.fwmurphy.com

CONTROL SYSTEMS & SERVICES DIVISION
 P.O. Box 1819; Rosenberg, Texas 77471; USA
 +1 281 633 4500 fax +1 281 633 4588
 e-mail sales@fwmurphy.com

MURPHY DE MEXICO, S.A. DE C.V.
 Blvd. Antonio Rocha Cordero 300, Fracción del Aguaje
 San Luis Potosí, S.L.P.; México 78384
 +52 444 8206264 fax +52 444 8206336
 Villahermosa Office +52 993 3162117
 e-mail ventas@murphymex.com.mx
 www.murphymex.com.mx

FRANK W. MURPHY, LTD.
 Church Rd.; Laverstock, Salisbury SP1 1QZ; U.K.
 +44 1722 410055 fax +44 1722 410088
 e-mail sales@fwmurphy.co.uk
 www.fwmurphy.co.uk

MURPHY SWITCH OF CALIFORNIA
 41343 12th Street West
 Palmdale, California 93551-1442; USA
 +1 661 272 4700 fax +1 661 947 7570
 e-mail sales@murphyswitch.com
 www.murphyswitch.com

MACQUARRIE CORPORATION
 1620 Hume Highway
 Campbellfield, Vic 3061; Australia
 +61 3 9358 5555 fax +61 3 9358 5558
 e-mail murphy@macquarrie.com.au



In order to consistently bring you the highest quality, full featured products, we reserve the right to change our specifications and designs at any time.